

Investigation of Bandwidth Request Mechanisms under Point-to-Multipoint Mode of WiMAX Networks

Qiang Ni, Brunel University

Alexey Vinel, State University of Aerospace Instrumentation

Yang Xiao, University of Alabama

Andrey Turlikov, State University of Aerospace Instrumentation

Tao Jiang, University of Michigan

ABSTRACT

The WiMAX standard specifies a metropolitan area broadband wireless access air interface. In order to support QoS for multimedia applications, various bandwidth request and scheduling mechanisms are suggested in WiMAX, in which a subscriber station can send request messages to a base station, and the base station can grant or reject the request according to the available radio resources. This article first compares two fundamental bandwidth request mechanisms specified in the standard, random access vs. polling under the point-to-multipoint mode, a mandatory transmission mode. Our results demonstrate that random access outperforms polling when the request rate is low. However, its performance degrades significantly when the channel is congested. Adaptive switching between random access and polling according to load can improve system performance. We also investigate the impact of channel noise on the random access request mechanism.

INTRODUCTION

Broadband wireless access (BWA) has gained a particular attention during the past few years. The widely successful IEEE 802.11 wireless LAN (WLAN) technologies were attempted in BWA applications along with a host of proprietary solutions. When the WLAN technologies were examined closely, it was evident that the overall design and feature set were not well suited for outdoor BWA applications. In response to this need, the IEEE 802 committee set up a working group in 1999 to develop a new standard for BWA applications, IEEE 802.16. Later, another industrial association, the Worldwide Interoperability for Microwave Access (WiMAX) Forum

[1], was formed to promote the 802.16 standards by defining the interoperability specifications between 802.16 products from different vendors. Thus, IEEE 802.16 networks are also often referred to as WiMAX networks.

The first IEEE 802.16 standard [2] was completed in October 2001, and addressed radio frequency bands from 10 to 66 GHz; thus, line of sight (LOS) is required between a base station (BS) and subscriber stations (SSs). In order to support more customers less expensively, an amendment called IEEE 802.16a was ratified in January 2003 by operating the physical (PHY) layer at lower frequency bands from 2 to 11 GHz, and thus allowing the possibility of non-LOS (NLOS) operation. In October 2004 the new standard 802.16-2004 [3] was published, which is actually an amalgamation of 802.16 and 802.16a specifying interoperable air interfaces from 2 to 66 GHz with a common medium access control (MAC) layer. Recently, the 802.16e standard [4, 5] was also ratified in December 2005, allowing upgrade from fixed BWA systems to mobile service provisioning up to vehicular speeds.

The 802.16 WiMAX air interface supports two operational modes: a mandatory point-to-multipoint (PMP) mode and an optional mesh mode. In PMP mode, a centralized BS controls all communications among the SSs and the BS, whereas in the mesh mode, SSs can also serve as routers by cooperative access control in a distributed manner. In this article we focus on centralized PMP mode, which is thought to be able to provide better quality of service (QoS) performance than distributed mesh mode; hence, PMP mode is the first choice of WiMAX operators. In a downlink subframe of PMP mode, the BS transmits a burst of MAC protocol data units (PDUs) using time-division multiplexing (TDM);

The work of Mr. Alexey Vinel was partly funded by the Russian Federal Agency for Education under project PHTL.2.2.2.3.9612.

in an uplink subframe of PMP mode, an SS transmits a burst of MAC PDUs to the BS using time-division multiple access (TDMA).

Resource management and allocation mechanisms are crucial to guarantee QoS performance in WiMAX networks. Under a centralized PMP architecture, multiple SSs share a common uplink to the BS on a demand basis. This means that if an SS needs some amount of bandwidth, it makes a reservation with the BS by sending a request. On accepting the request from an SS, the BS scheduler should determine and grant it a transmission opportunity in time slots by using some scheduling algorithms, which should take into account the requirements from all authorized SSs and the available channel resources. Two main methods are suggested in the WiMAX standard to offer transmission opportunities for SSs to send their bandwidth request (BW-REQ) messages: *centralized polling* and *contention-based random access*. In the first case each SS station is only allowed to send its request when it is polled by the BS; in the latter all SSs contend to obtain transmission opportunities for sending requests using contention resolution mechanisms.

The performance comparison between these two access methods, random access and polling, has been studied within the framework of IEEE 802.11 WLANs (e.g., [6, 7]) — distributed coordination function (DCF) vs. point coordination function (PCF). DCF is a random access scheme based on carrier sense multiple access (CSMA) with binary exponential backoff (BEB) collision resolution, also called CSMA with collision avoidance (CSMA/CA). The DCF performs well under low load conditions. However, its performance degrades rapidly when the number of terminals increases. The lack of QoS support caused by collisions in high load conditions becomes a key problem with DCF. On the other hand, polling-based PCF was introduced to support QoS for multimedia applications and can only be used in a centralized mode. However, PCF was not successfully deployed mainly due to worry that hardware implementation of the PCF scheduling algorithms would be too complicated and also too expensive for most WiFi customers. Recently, in September 2005, a new WLAN standard, 802.11e, was approved that combines these two access mechanisms together into a single MAC function called hybrid coordination function (HCF) [8]. However, the performance of HCF is still under investigation, and whether or not it will finally be accepted by customers is at present unknown.

As for 802.16 WiMAX networks, to the best of our knowledge, by now only a few research projects (e.g., [9, 10]) have been reported comparing the performance of these two types of BW-REQ mechanisms as well as proposing vendors' efficient methods to schedule both BW-REQ and data messages: the BEB algorithm within the framework of IEEE 802.16 was first investigated in [9] under a "saturation" condition assumption using an analytical approach. However, this saturation assumption is too strong since networks do not typically operate in saturation conditions (e.g., most Internet applications exhibit bursty traffic characteristics). An unsatu-

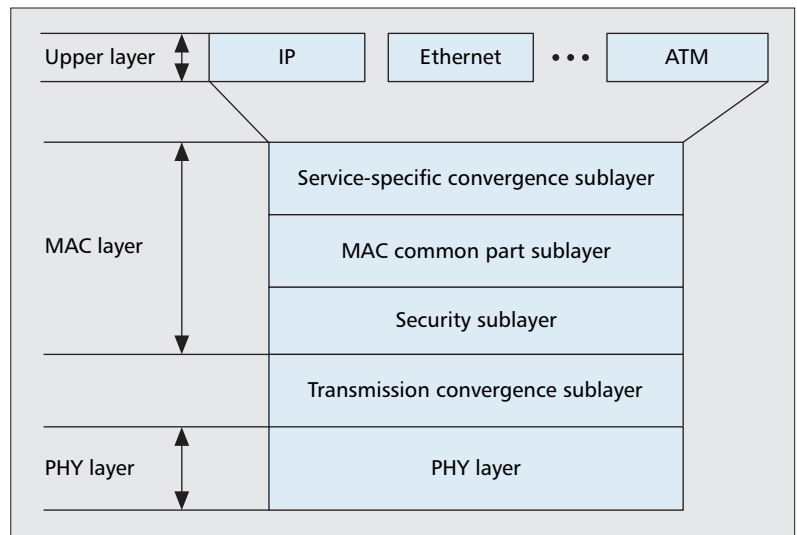

■ **Figure 1.** Protocol architecture of IEEE 802.16 WiMAX networks.

rated mathematical model was recently proposed in [10] for the analysis of WiMAX networks under the assumption of error-free channel conditions.

In this article we thoroughly investigate various BW-REQ mechanisms for WiMAX considering both error-free and error-prone channels with arbitrary request arrival rates. Without losing the generality of the problem, a Bernoulli request arrival process is chosen with a finite number of stations. We limit our analysis to investigation of BW-REQ delay performance during the reservation process, where actual data packet transmission was not included. This allows us to first focus our attention on improving the efficiency of the BW-REQ algorithms as it is a fundamental component for complete analysis of the 802.16 MAC protocols.

The rest of this article is organized as follows. We first describe the PHY and MAC protocols specified in the WiMAX standard, and different BW-REQ mechanisms are also introduced. We then present the system models for analyzing the performance of random access and polling schemes. Finally, experimental results and a conclusion are provided.

OVERVIEW OF WiMAX AND BW-REQ MECHANISMS

The protocol architecture of the WiMAX standard is shown in Fig. 1, where a common MAC layer is defined to associate with various PHY layer specifications. The interface between different PHY specifications and the MAC is accommodated as a separate sublayer, the transmission convergence sublayer, which hides the detailed PHY technologies from the MAC. On top of the MAC, a service-specific convergence sublayer is specified to facilitate various types of applications such as IP, asynchronous transfer mode (ATM), Ethernet, and Point-to-Point Protocol (PPP) services. A security support sublayer is also included in the MAC, providing authentication, secure key exchange, encryption, and so on. The key components of WiMAX PHY and

The WiMAX MAC layer is connection-oriented, and is designed with QoS support by allowing bandwidth reservation and flexible implementation of resource scheduling/admission control mechanisms. All services are mapped to connections.

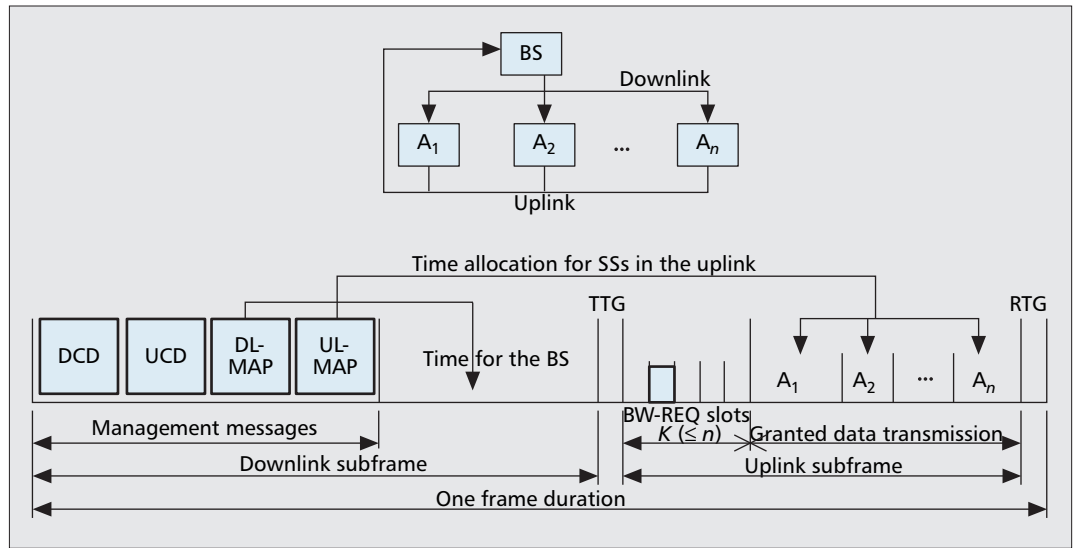

■ Figure 2. TDMA/TDD operation of WiMAX networks in PMP mode.

MAC protocols, and proposed BW-REQ mechanisms are described in the following three subsections.

PHY LAYER PROTOCOLS

The PHY layer in the 10–66 GHz band is based on single-carrier modulation, which is referred to as WirelessMAN-SC and requires LOS transmission given that the operation frequency is so high. Three other PHY air interface specifications are proposed for the lower frequency bands of 2–11 GHz, which actually helps to mitigate the effects of multipath fading, and thus could offer cheap and flexible solutions to WiMAX customers:

- WirelessMAN-SCa, which uses a special single-carrier modulation format designed for NLOS operation
- WirelessMAN-OFDM, which uses orthogonal frequency-division multiplexing (OFDM) with 256 carriers
- WirelessMAN-OFDMA, which uses orthogonal frequency-division multiplexing access (OFDMA) with a total number of 2048 carriers

Different levels of modulation schemes, including binary phase shift keying (BPSK), quaternary PSK (QPSK), 16-quadrature amplitude modulation (QAM), and 64-QAM, can be chosen depending on channel conditions. Furthermore, optional features of intelligent adaptive antenna systems (AASs) are also allowed to improve the spectral efficiency of the system. In the 10–66 GHz band, channel bandwidths of 20, 25 (typical U.S. allocation), or 28 MHz (typical European allocation) can be used. On the other hand, in the 2–11 GHz band, a variable channel bandwidth has been defined that can be an integer multiple of 1.25 MHz, 1.5 MHz, and 1.75 MHz, but no more than 28 MHz.

MAC LAYER PROTOCOLS

The WiMAX MAC layer is connection-oriented, and designed with QoS support by allowing bandwidth reservation and flexible implementation of resource scheduling/admission control

mechanisms. All services are mapped to connections. Any application from an upper layer first has to establish a connection with the BS. The BS then assigns each connection a unique connection ID (CID). This mechanism applies to all services, including inherently connectionless services, in order to provide a mechanism for requesting bandwidth, associating QoS and traffic parameters, transporting and routing data, and other actions associated with the services. Both time-division duplexing (TDD) and frequency-division duplexing (FDD) modes are supported in WiMAX. In the TDD case each MAC frame includes a downlink subframe followed by an uplink subframe; in the FDD case, the uplink subframe could be slightly delayed with respect to the downlink subframe so that the SSs can receive necessary information about the uplink channel access from the downlink.

Under the PMP architecture, all transmissions between the BS and SSs are coordinated by the BS. In this article we only focus on the TDMA/TDD transmission mode, where similar analysis can also be applied to FDD configuration. The TDMA/TDD frame structure is illustrated in Fig. 2; it consists of a downlink subframe for transmission from the BS to SSs and an uplink subframe for transmissions in the reverse direction. The Tx/Rx transition gap (TTG) and the Rx/Tx transition gap (RTG) are specified between the downlink and uplink subframes, and between the uplink and following downlink subframes in the next frame duration to allow SS terminals to turn around from reception to transmission and vice versa. In the downlink subframe, both the downlink MAP (DL-MAP) and uplink MAP (UL-MAP) messages are transmitted, which comprise the bandwidth allocations for data transmission in both downlink and uplink directions, respectively. Moreover, the lengths of uplink and downlink subframes are determined dynamically by the BS and are broadcast to the SSs through UL-MAP and DL-MAP messages at the beginning of each frame. Therefore, each SS knows when and how long to receive data from and transmit data to

the BS. This functionality considers that most Internet applications have more downstream traffic than upstream (known as bandwidth asymmetry), and the bandwidth allocated to each direction can be tuned dynamically to match the traffic in the corresponding direction.

Another important management message, which is interconnected with UL-MAP, is called an uplink channel descriptor (UCD), which can be periodically transmitted in the downlink subframe (Fig. 2). The values of the minimum backoff window, W_{\min} , and maximum backoff window, W_{\max} , are defined in this message; they are used for the contention resolution algorithm and are explained in detail later. The uplink subframe contains transmission opportunities scheduled for the purpose of sending BW-REQ messages in which BW-REQ messages can be transmitted, which serves for SSs to indicate to the BS that they need UL bandwidth allocation. The BS controls both the number of transmission opportunities for BW-REQ and data packet transmission through the UL-MAP message.

An SS may establish multiple connections with a BS. While one BW-REQ request should be made for each connection, a grant is only allowed to be awarded to a station (GPSS) in the 2004 standard [3]. In the old version of the standard [2] either connection- (GPC) or GPSS-based requests are allowed. By choosing the GPSS aggregation method, a WiMAX system is supposed to reduce the granting workload of the BS when there are many connections per SS, and the winning SS should redistribute bandwidth among multiple connections maintaining the agreed upon QoS levels.

BW-REQ MECHANISMS: RANDOM ACCESS AND POLLING

A BW-REQ can be issued either a standalone request or an uplink data packet as a piggyback request. Note that the capability of piggyback request is optional. In order to determine which SS is allowed to transmit its BW-REQ from multiple candidates, two main methods are suggested in the standard, contention-based random access and contention-free based polling. In both schemes, no explicit acknowledgment (ACK) frame is sent back to indicate whether a BW-REQ message is successfully transmitted or distorted (possibly due to channel noise or collision), or how much bandwidth the SS is granted. If a grant is not given within a special timeout, T16 [3], the SS should determine that its BW-REQ was corrupted, and then start a contention resolution process. On the other hand, on receiving a grant within the timeout, the SS will stop contention resolution and use the allocated bandwidth for uplink transmission of data packets or to piggyback an additional request if necessary. Furthermore, the SS might know how much bandwidth is awarded by observing the following grant from the BS. Due to different scheduling algorithms at a BS, a grant may be given at any time.

With random access, an SS transmits a BW-REQ during a predefined contention period, and a random backoff mechanism is used to resolve contention among BW-REQ PDUs from

multiple SSs. The mandatory method of random access contention resolution used in WiMAX is based on a truncated binary exponential backoff (BEB) scheme without carrier sensing in contrast to the widely used CSMA/CA mechanism in IEEE 802.11 WiFi networks. Before each transmission attempt of a BW-REQ, an SS station uniformly chooses an integer number from the interval of $[0, W_i - 1]$, where W_i denotes the current value of its backoff window. The chosen value, also referred to as a backoff counter, indicates the number of slots the station has to wait before the transmission of a request. For the first transmission attempt, the backoff window size starts with the minimal value denoted by W_{\min} . Upon each transmission failure, a station should double its backoff window value. Hence, the backoff window after the i -th collisions, W_i , will become $2^i W_{\min}$, until reaching the maximum value W_{\max} ($= 2^m W_{\min}$), where m is the maximum backoff stage. Both W_{\min} and W_{\max} should be defined by the BS, but no optimal parameters are provided in the WiMAX standard. On each successful transmission, the backoff window size should be set back to the minimum value W_{\min} assuming that the channel is free again.

When polling-based BW-REQ allocation is chosen, the BS shall maintain a list of registered SSs and poll them according to this list. Each SS is only allowed to transmit the BW-REQ message after it is polled. Actually, the poll schedule information for polling-based BW-REQ is carried by the UL-MAP and UCD in the downlink subframes as shown in Fig. 2. Note that scheduling algorithms for polling are vendor-dependent and not specified in the standard. One may choose a simple round-robin scheduler to poll each SS sequentially in the polling list, but other priority-based polling mechanisms might also be used for BW-REQ scheduling if different QoS levels are required by different SSs. Furthermore, the polling allocation can be issued to a group of SSs. Allocation schedules to groups are also indicated in UL-MAP and UCD. This grouping mechanism is particularly important when available bandwidth is insufficient for a BS to individually poll many inactive SSs, and thus only active groups of SSs should be polled in multicast groups, or a broadcast poll may be used to save resource usage. Certain CIDs are reserved for multicast groups and broadcast messages as specified in the standard.

It should be noted that polling-based BW-REQ is particularly important for AAS subscribers since they might not be able to request bandwidth using the usual random access contention mechanism. This happens because the adaptive array may not have a beam directed at the SS when it is requesting bandwidth, and the BW-REQ will be lost. In order to avoid this situation, a good solution is for the BS to poll those AAS SSs to obtain their BW-REQ information.

SYSTEM MODELS FOR BW-REQ MECHANISMS

In order to analyze the above mentioned two types of BW-REQ mechanisms, we present the following system models in this section. Let us

It should be noted that polling-based BW-REQ is particularly important for AAS subscribers since they might not be able to request bandwidth using the usual random-access contention mechanism.

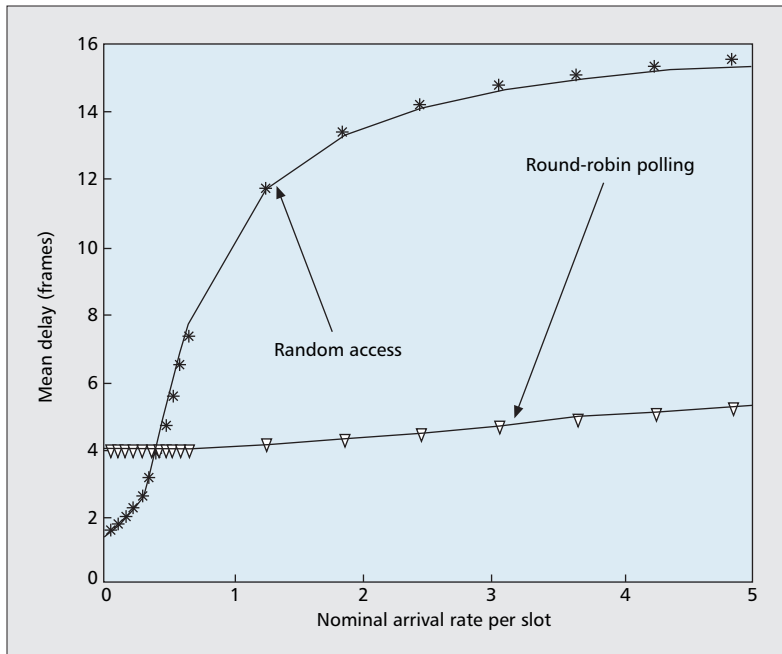

■ **Figure 3.** Performance comparison: random access vs. polling ($n = 30$, $K = 5$, $l = 1$, $m = 4$).

consider a PMP system in which there is one BS, and the total number of SS stations is n . Each SS station has a buffer sufficient to store exactly one request. A station that has a request at the considered moment of time is referred to as *active*, otherwise it is called *non-active*. According to the WiMAX standard [3], each SS may potentially establish several connections with different negotiated QoS parameters with the BS, and a BW-REQ should be issued per connection. In this work we assume that each SS has only one connection at a given time. In the case of multiple connections per SS, n refers to the total number of connections in the system.

During one frame duration, each non-active SS generates a request with a probability $\pi = \lambda/n$, where λ is the mean number of requests generated by the system in that frame if all SSs are non-active. This new request is put into the buffer and transmitted no earlier than the next frame transmission. Since only non-active stations can generate a request, the actual request arrival rate in a frame can sometimes be lower than λ depending on the system load.

In this article we focus our analysis on uplink BW-REQ transmission. The transmission of data packets in both directions is ignored. The time duration of each frame is fixed, in which K BW-REQ slots are included, as shown in Fig. 2. The duration of a slot corresponds to the time needed for a BW-REQ transmission, which is PHY-layer-dependent.

The delay performance of the system is defined as the time interval (measured in frames) from the moment of issuing the BW-REQ until the moment the station knows that the request has been successfully transmitted. Indeed, the value of mean delay for a particular BW-REQ mechanism is a significant performance metric, indicating its efficiency, by which

we choose to compare different BW-REQ mechanisms.

Both error-free and error-prone channels are considered in our model. For error-free channels, if multiple BW-REQ transmissions happen simultaneously, a collision is assumed, and this is the only cause for BW-REQ corruption. Then the SSs must start a contention resolution process. However, when a channel is error-prone, a BW-REQ message may also be corrupted due to poor channel conditions, such as path loss, multipath fading, thermal noise, or interference from other emitting sources nearby. These additional damaging effects should be modeled in order to investigate effective solutions as actual channels are normally noisy.

MODELING RANDOM ACCESS BW-REQ MECHANISMS

Note that each TDMA/TDD frame comprises K fixed-size¹ slots for the random access. In practice, the value of K as well as its proportion to the whole frame size should influence the performance of the MAC layer protocol: if K is too small, many BW-REQ messages may be queued in the buffer, and might be dropped depending on the implementation policy of the request queue and thus degrade the performance. On the other hand, should K be too large, some request slots may be wasted due to the fact that not enough BW-REQ messages contend to access them. Intuitively, this trade-off should depend on the load of BW-REQ, and is thus linked to the number of SSs associated with the BS and the application characteristics of those SSs. In this article we fix the value of K for each experiment, which means that once K is chosen as any value at the beginning of the experiment, it is not changed. The optimization of K will be our future work when actual data packet transmission is also modeled.

In addition, the standard does not define any relationship between the parameters W_{\min} , W_{\max} , and K . Note that if $W_{\min} < K$, some time slots will never be used during the first transmission attempt. Hence, we suggest that $W_{\min} \geq K$. For simplicity, we choose $W_{\min} = lK$, where l is an integer number ($l \geq 1$), in order to uniformly distribute the transmission attempts over the available random access slots.

When the channel is considered error-free, the transmission of one BW-REQ is treated as successful if exactly one station transmits in a slot; otherwise, a collision is considered to have occurred. In this system the number of active stations at the beginning of each frame is a stochastic process. It can be modeled by a discrete-time Markov chain, and its transition probabilities can be determined from the chain. Assuming that the request arrival is modeled by a Bernoulli process, the number of new requests appearing in the system for the frame duration has a binomial distribution with a parameter π ($= \lambda/n$). Thus, the probability $\psi_{j,i}$ that j ($0 \leq j \leq n$) new requests appear in the system for the frame duration, under the condition that there are i ($0 \leq i \leq n$) active stations, can be obtained as

¹ In this work link adaptation is not considered in which modulation schemes can be tuned dynamically to accommodate varying channel conditions (e.g., SNR); hence, the slot duration is assumed fixed once a modulation scheme is selected.

$$\Psi_{j,i} = \binom{n-i}{j} \pi^j (1-\pi)^{n-i-j}.$$

Due to space limits, we omit the detailed mathematical manipulations for the above Markov chain; the detailed model derivation is presented in [10]. Note that this Markov chain is ergodic, and its solution is unique. Hence, the average number of BW-REQ messages in the system can be determined (denoted \bar{N}). Using Little's law and taking into account the waiting time till the beginning of next frame, the mean delay for random access BW-REQ transmission can be obtained by

$$\bar{d} = 0.5 + \bar{N} \frac{n}{(n-\bar{N})\lambda}.$$

If the channel is error-prone, a further frame error rate has to be added to the above model. We assume that the wireless channel is Gaussian, in which each bit has the same bit error probability, and bit errors are identically and independently distributed (i.i.d.) over the whole BW-REQ frame. While Gaussian channel assumption is not realistic, it is widely used due to its simplicity. The consideration of other sophisticated channel models will be our future work. Here, p_e denotes the probability of a request corrupted by channel noise.

MODELING POLLING-BASED BW-REQ MECHANISMS

No specific polling algorithms are defined in the standard. The following simple round-robin polling scheme is considered for the analysis: Each of K slots is assigned equally to all of the n stations in the system. In most cases, n is larger than K .² Hence, round-robin polling can be modeled by means of a Markov chain. The mean delay can be obtained by $\bar{d}_{\text{poll}} = 0.5 + ((1-\pi)^q + q(1-\pi)^{q-1}\pi^2 + q\pi - 1)/(\pi - \pi(1-\pi)^q)$, where $q = \lceil n/K \rceil$ denotes the number of frames needed to poll all the stations once.

PERFORMANCE ANALYSIS OF BW-REQ MECHANISMS

In this section we compare the two types of BW-REQ mechanisms, random access and polling, by using the proposed models above under both error-free and error-prone channel conditions. For the WiMAX PHY layer, 256-carrier OFDM and 5 MHz bandwidth are chosen. The frame duration is set to 2.5 ms. In the following plots the nominal arrival rate per slot is chosen and is defined by λ/K (considering K slots per frame). The measured mean delay is in units of frames.

RANDOM ACCESS VS. POLLING

In this experiment a channel is assumed to be error-free. The total number of SSS is set to $n = 30$, and the total number of reservation slots is chosen as $K = 5$. The experimental results are shown in Fig. 3. The delay of random access

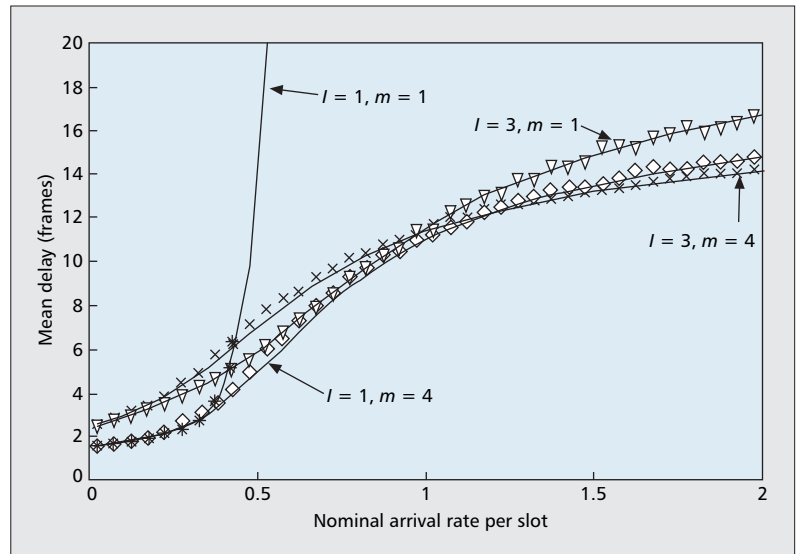

Figure 4. Performance of random access in error-free channels ($n = 25$, $K = 4$).

is lower than that of polling when the nominal arrival rate is small; however, it degrades significantly due to increasing collisions when the nominal arrival rate is high. Indeed, random access is more efficient than centralized polling when the request rate is low. Polling starts with a slightly higher waiting time than random access, but delays do not degrade too much with an increasing arrival rate. The experiments show that adaptive switching between random access and polling according to channel load can improve system performance. In particular, when a channel is congested, polling or group-based polling should be preferred. The crossing point between them depends on not only the request arrival rate, but also the number of SSS in the system as well as other backoff parameters, further investigated in the following. This observation is similar to the comparison between the DCF and PCF in WiFi networks [6].

OPTIMAL RANDOM ACCESS IN AN ERROR-FREE CHANNEL

To further investigate random access in an error-free channel, let us consider the scenario with n ($= 25$) stations, K ($= 4$) contention slots, and different BEB parameters (l, m), as shown in Fig. 4. When $l = 1$ and $m = 1$, the mean delay increases exponentially to unacceptably high values after the nominal arrival rate per slot exceeds about 0.4. This shows that choosing small values of l and m will lead to a large number of trials and collisions and hence degrade delay performance. By increasing the value of backoff stages m (e.g., $m = 4$), the risk of collisions is reduced, so the mean delay is also controlled. On the other hand, increasing the value of l (e.g., $l = 3$) leads to higher mean delay for small arrival rate values. For practical implementation, we suggest using a small value of l (e.g., $l = 1$, i.e., $W_{\min} = K$). The operator can provide good performance for different request arrival rates.

² If $n \leq K$, the system will be very lightly loaded, and there are more slots than the total number of SSS in the system. All the SSS will be able to send BW-REQs within a frame. The delay can be easily determined, i.e., one frame duration.

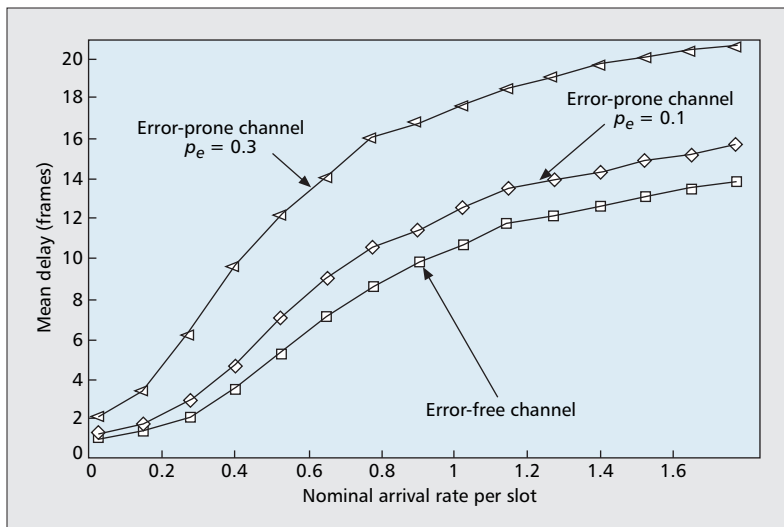

■ Figure 5. Performance of random access in noisy channels ($n = 25$, $K = 4$, $l = 1$, $m = 4$).

PERFORMANCE ANALYSIS OF RANDOM ACCESS IN A NOISY CHANNEL

The impact of channel noise on delay performance is shown in Fig. 5. In this experiment the two system parameters (n , K) are kept the same as in the last experiment: $n = 25$ and $K = 4$. Now, let us set $l = 1$ and $m = 4$. The channel noise level is varied by changing the values of p_e . It is clear that channel noise significantly degrades the delay performance of BW-REQ. The influence is particularly high with a higher frame error rate value. This is due to the fact that channel noise increases the transmission failure probability of BW-REQ messages, and more retransmission is caused, which further increases the contention when a channel is congested.

CONCLUSIONS

In this article we have studied the delay performance of the two BW-REQ mechanisms proposed in the WiMAX standard, random access and polling, using our system model. The performance evaluation results show that random access is more efficient than polling when the request rate is low. However, its performance degrades rapidly when channel load increases. Adaptive switching between random access and polling can improve system performance. It also demonstrates that the influence of channel noise on the BW-REQ mechanism is not negligible and needs further investigation. Future work includes performance analysis of the complete WiMAX MAC protocols, including both bandwidth request and data packet scheduling and admission control algorithms with various channel conditions.

REFERENCES

[1] WiMAX Forum; <http://www.wimaxforum.org/>
 [2] IEEE Std. 802.16-2001, "Local and Metropolitan Area Networks, Part 16: Air Interface for Fixed Broadband Wireless Access Systems," 2001.

[3] IEEE Std. 802.16-2004, "Local and Metropolitan Area Networks, Part 16: Air Interface for Fixed Broadband Wireless Access Systems," Oct. 2004.
 [4] IEEE Std. 802.16e-2005, "Local and Metropolitan Area Networks, Part 16: Air Interface for Fixed and Mobile Broadband Wireless Access Systems," Dec. 2005.
 [5] Y. Xiao, "Energy Saving Mechanism in the IEEE 802.16e Wireless MAN," *IEEE Commun. Lett.*, vol. 9, no. 7, July 2005, pp. 595-98.
 [6] A. Kopsel, J.-P. Ebert, and A. Wolisz, "A Performance Comparison of Point and Distributed Coordination Function of an IEEE 802.11 WLAN in the Presence of Real-Time Requirements," *Proc. 7th Int'l. Wksp. MoMuc '000*, Waseda, Japan, Oct. 2000.
 [7] V. W. Vishnevsky, A. I. Lyakhov, and N. N. Guzakov, "Evaluation of the Maximal Carrying Capacity of Wireless Internet Access," *Automation and Remote Control*, vol. 65, no. 9, part 2, Sept. 2004.
 [8] IEEE Std. 802.11e-2005, "Local and Metropolitan Area Networks, Part 11: Wireless LAN MAC and PHY Specifications: MAC QoS Enhancements," Sept. 2005.
 [9] A. Vinel et al., "Performance Analysis of the Random Access in IEEE 802.16," *Proc. IEEE PIMRC '05*.
 [10] A. Vinel et al., "Efficient Request Mechanisms Usage in IEEE 802.16," *Proc. IEEE GLOBECOM '06*.

BIOGRAPHIES

QIANG NI (Qiang.Ni@ieee.org) [M] is a faculty member in the School of Engineering and Design, Brunel University, West London, United Kingdom, where he heads the Intelligent Wireless Communication Networking Group. Prior to that he was with the Hamilton Institute, National University of Ireland Maynooth (2004-2005) and Planete Group INRIA France (2001-2004), respectively. His research interests are intelligent wireless networking and mobile communications including WLAN, WiMAX, wireless PAN, and 4G mobile networks. He received his Ph.D. degree in 1999 from Huazhong University of Science and Technology, China.

ALEXEY VINEL (vinel@ieee.org) is a Ph.D. student in the Information Systems Department of St.-Petersburg State University of Aerospace Instrumentation (SUAI), Russia. He received his Bachelor and Master degrees in information systems from SUAI in 2003 and 2005, respectively, both with honours. During his study, he did a half-year internship at Siemens AG, Munich, Germany. His research interests include random multiple access algorithms and performance evaluation of wireless networks.

YANG XIAO [SM] (yangxiao@ieee.org) is currently with the Department of Computer Science at the University of Alabama. He was a voting member of the IEEE 802.11 Working Group from 2001 to 2004. He currently serves as Editor-in-Chief for *International Journal of Security and Networks*, *International Journal of Sensor Networks*, and *International Journal of Telemedicine and Applications*. He serves as a referee/reviewer for many funding agencies, and is also a panelist for NSF and a member of the Canada Foundation for Innovation's Telecommunications expert committee. He has served as Technical Program Chair for more than 80 conferences, including INFOCOM, ICDCS, ICC, GLOBECOM, and WCNC. His research areas are wireless networks, mobile computing, and network security.

ANDREY TURLIKOV is an associate professor in the Information Systems Department of SUAI. He graduated from Leningrad State Institute of Aerospace Instrumentation (now SUAI) in 1980 and received his Ph.D. degree in 1986. Since 1987 he has been involved in teaching. His research interests include multiple access systems and real-time data transmission protocols. He is the author of more than 50 publications.

TAO JIANG [M] (Tao.Jiang@ieee.org) is a postdoctoral researcher at the Department of Electronic and Computer Engineering, University of Michigan, Dearborn. He received B.S. and M.S. degrees in applied geophysics from China University of Geosciences, Wuhan, in 1997 and 2000, respectively, and a Ph.D. degree in information and communication engineering from Huazhong University of Science and Technology, Wuhan, P. R. China, in April 2004. His current research interests include the areas of wireless communications and corresponding signal processing, especially for OFDM and MIMO systems, cooperative networks, cognitive radio, and ultra wideband communications.